



**Electronic Concentrate  
Management System  
with Automatic Flush  
3435-0132 (12VDC) and 3435-0133 (24VDC)**

**INSTALLATION AND  
OPERATION MANUAL**

Unit Serial Number _____
--------------------------------

All quality FoamPro products are ruggedly designed, accurately machined, carefully assembled, thoroughly inspected and tested. In order to maintain the high quality of your unit, and to keep it in a ready condition, it is important to follow the instructions on care and operation. Proper use and good preventive maintenance will lengthen the life of your unit. ALWAYS INCLUDE THE UNIT SERIAL NUMBER IN CORRESPONDENCE.

# TABLE OF CONTENTS

SECTION	PAGE
1 SAFETY .....	1
2 A QUICK LOOK AT HOW THE SYSTEM WORKS .....	2
3 WHAT YOU GET .....	2
4 WHAT YOU SUPPLY .....	3
5 PLAN AHEAD.....	4
6 PLUMBING THE SYSTEM .....	4 & 5
7 ELECTRONIC COMPONENT INSTALLATION .....	6
8 OPERATING INSTRUCTIONS .....	10
9 TROUBLESHOOTING .....	10
10 PARTS IDENTIFICATION.....	11
11 WARRANTY .....	BACK PAGE

---

# 1 Safety

*Please read all of the following safety precautions and follow them carefully. They are important to the prevention of personal injury or damage to the equipment.*

1. **Always disconnect the power source** before servicing any part of the Dual-Tank system.
2. **Release all pressure** within the system before servicing any of its component parts.
3. **Drain all liquids** from the system before servicing any of its component parts.
4. **Check all hoses** for weak or worn conditions monthly. Make sure that all connections and fittings are tight and secure.
5. **Use inlet pipe**, hose, and fittings—from the foam tanks to the selector valve—that are rated for 23 inches Hg vacuum (584 mm Hg) and 50 psi (3 BAR) pressure and are compatible with foam agents.
6. **Use inlet pipe**, hose and fittings:
  - from the selector valve to the inlet of the foam pump.
  - and from the flush line connector to the flush solenoid on the selector valve.Use inlet pipe, hose and fittings that are rated at or above the maximum pressure (400 psi minimum) rating at which the water pump system may operate.
7. **Any electrical system** has the potential to cause sparks during service. Eliminate explosive or hazardous environments during service/repair.
8. **The components and fittings** used in this system must be compatible with the foam concentrates used and pressures at which the pump system operates.
9. **CAUTION:** Do not operate the system at or above a temperature of 160° F (71°C).
10. **CAUTION:** Make sure the electrical source of power for the unit is a constant 12-volt (3435-0132) or 24-volt (3435-0133), negative ground DC system.
11. **CAUTION:** Periodically inspect all foam pump and all system components. Perform routine preventive maintenance as required.

# 2 A Quick Look at How the System Works

The Electronic Concentrate Management System allows for the connection of two foam reservoirs into your FoamPro Foam Proportioning System. The system provides an interface with the main system controller and a flush position.

The interface with the system controller supplies Dual-Tank calibration and Dual-Tank injection rates. The Dual-Tank calibration allows accurate calibration of each foam concentration tank separately and automatic switching of that calibration when changing tanks. The Dual-Tank injection rate allows the presetting of the defaulted injection rate for each foam concentrate tank. This feature will also automatically switch when changing tanks.

The electronics provide an automatic 8-second flush when switching from one tank to another. When the selector is left in the flush position (center position), water discharge pressure is

open to the suction of the foam pump for approximately 1 minute. Since the discharge of the foam pump is piped to the water discharge, flushing action will take place when the foam pump is run until it is switched to either A or B tank.

The system comes with a placard, switch, lights that indicate which tank is being used, and a 20 foot interface cable. The cable allows the usage of the Dual-Tank calibration and defaulted injection rate features in the system controller. An optional flush indicator lamp may be wired into the system to provide positive indication that the flush or off position has been selected.

A tank level sensor must be provided for each foam concentration reservoir. The internal switches will signal the system controller when the tank being used is low or out of foam concentrate. The tank not being used is not monitored for low concentrate.

# 3 What You Get

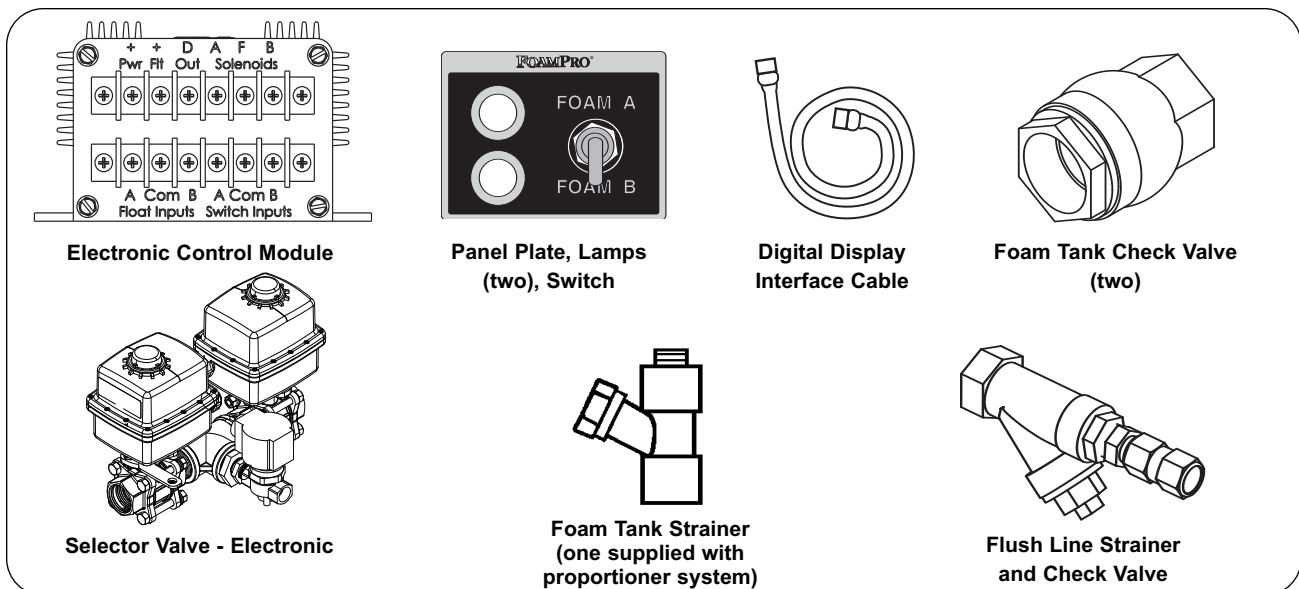

- Electronic Control Module**
- Panel Plate, Lamps (two), Switch**
- Digital Display Interface Cable**
- Foam Tank Check Valve (two)**
- Selector Valve - Electronic**
- Foam Tank Strainer (one supplied with proportioner system)**
- Flush Line Strainer and Check Valve**

### Optional System Accessories Available

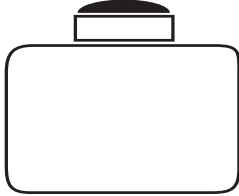

**Foam Tank(s)**  
 8 gallon, polypropylene  
 (P/N 1530-0005)  
 12 gallon, polypropylene  
 (P/N 1530-0012)  
 20 gallon, polypropylene  
 (P/N 1530-0022)  
 Requires additional hardware for compliance with the N.F.P.A.

**Tank Level Sensors**  
 (One for each foam cell is required)

<b>Side-Mount</b>	<b>or</b>	<b>Vertical-Mount</b>
1/2" NPT thread (P/N 2510-0032)		1/8" NPT thread (P/N 2510-0028)

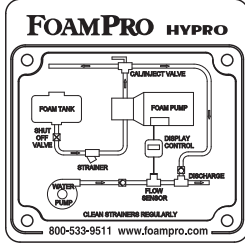

**Placard**  
 (P/N 6032-0016)

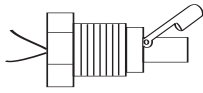
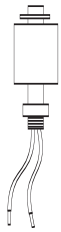
# 4 What You Supply

#### ITEMS NEEDED:

1. Shut-off valves, quarter turn, 1" NPT (two), (brass or stainless steel)
2. Pipe tee, to suit water pipe and flush line size
3. Low pressure, clear suction hoses (1" minimum inside diameter)
4. Foam tanks (two) size to customer's specifications.
5. High pressure hose

#### FOAM TANK TO INTAKE OF FOAM PUMP

Fittings and hoses from the foam tank to the inlet of the selector valves will need to be supplied by the installer. Use 1" inside diameter hose. Use components that are rated for 23 inches (584 mm) Hg and 50 psi (3 BAR)

working pressure. Hose from the selector valve to the foam pump should be at least 400 psi (28 BAR) or greater capacity to withstand the water pressure of the water pump during flushing. All hoses and fittings must be compatible with the foam concentrates that will be used.

#### NOTES:

NFPA requirement: A foam injection check valve is required in the foam pump discharge to prevent backflow of water into the foam concentrate injection system.

#### SYSTEM WIRING

Standard automotive 16 AWG wire or larger may be used. It is recommended that wiring be bundled with wire ties and protected with loom.

# 5 Plan Ahead

Because of the potential differences in fire apparatus plumbing and foam system configuration, it is not practical to depict exactly how each FoamPro unit will be installed on a particular apparatus. Most of the information contained in the following sections, however, will apply to any situation.

**Read these sections thoroughly. Plan and design where and how to install this equipment in the apparatus *before beginning the actual installation.*** The following diagrams provide guidelines for the location of the system components.

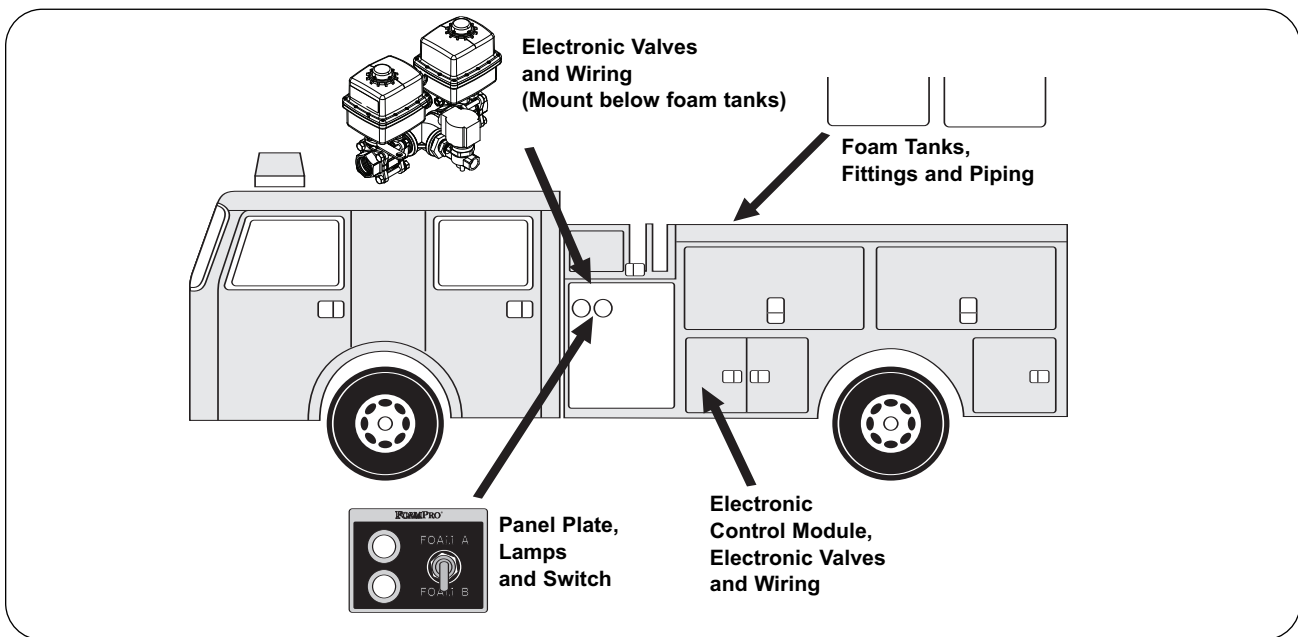

# 6 Plumbing the System

The system diagram on the following page shows the foam tank to foam pump inlet piping. Always use hose, fittings and pipe that are compatible with foam agents. Make all connections vacuum tight to ensure proper operation.

Mount the selector valve in a position to allow gravity feed from the foam tank through the valve and to the foam pump.

The flush solenoid requires mounting so that the coils are vertical above the valve portion of

the valve (located on a horizontal plane). If the flush solenoid is removed from the main valve assembly, ensure that the valve port and coil orientation remain the same.

One (1) strainer is provided with the FoamPro System to be used for the flush line. Two (2) strainers and two (2) 1" check valves are provided with the Concentrate Management System and are to be used between the selector valve and the foam cells. One (1) 3/8" check valve is provided for the flush line.

### Concentrate Management Flush Valve Plumbing Diagram

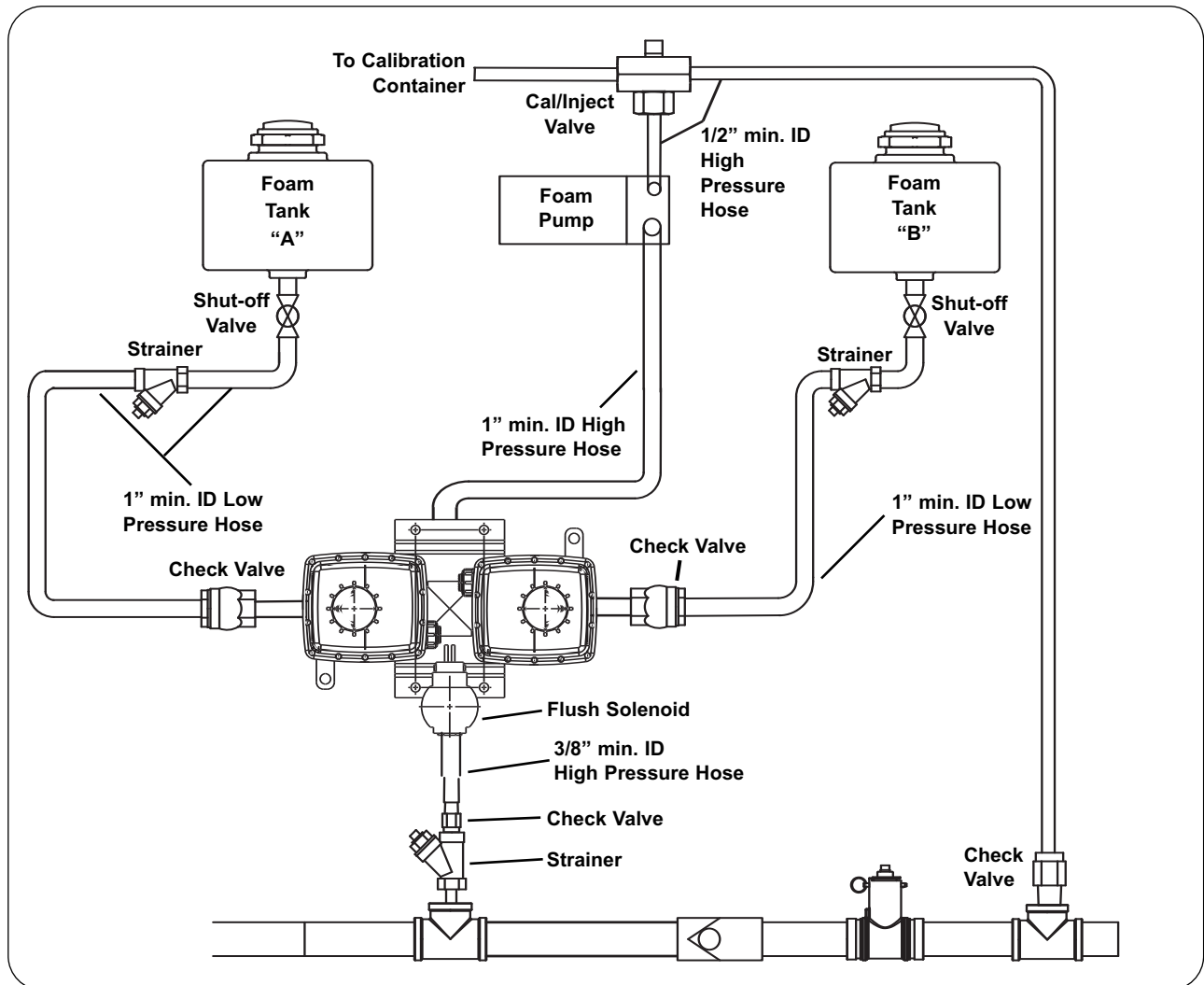

#### NOTES:

1. Make sure the strainers are mounted in an accessible location because they require regular maintenance.
2. Low-pressure hoses and fittings from the foam tanks to the selector valve should be good for 23 inches (584 mm) Hg vacuum and 50 psi (3 BAR) working pressure. All other hoses should be rated for full discharge pressure of the main water pump [400 psig (28 BAR) minimum working pressure].
3. Hoses from each tank should be connected to the valve appropriate 1" ball port. The flush line should always be connected to the attached solenoid valve.
4. All hoses in the above diagram are high pressure [400 psig (28 BAR) minimum working pressure] unless otherwise noted.
5. It is recommended that the low-pressure hose used on the foam suction be of clear construction so foam flow may be observed. See the diagram above.

# 7 Electronic Component Installation

The diagram on Page 8 shows how to wire the electrical components. The Concentrate Management System (CMS) draws less than 5 amps.

Locate and mount the control module in an area on the apparatus that is readily accessible. The mounting dimensions are provided in the diagram on Page 7. Although the control module is designed to be watertight, it must be mounted away from water and road spray to avoid excessive electrical terminal corrosion.

Use of standard 16 AWG or larger automotive wire that is grease and fuel resistant is recommended. When connecting the wires to the terminals, remove only 1/4 inch of the insulation from the end of the wire. Support all wiring to prevent short circuits at the terminal block.

Provide a 7 amp fused circuit from a relay connected to the fire pump switch. Installed in this manner, the CMS will only cycle through the FLUSH mode when the fire pump is engaged. If not installed in this manner, the CMS will cycle through the FLUSH mode every time the apparatus is powered up, causing a loss of foam or flush water to accumulate under the apparatus. This may cause the apparatus floor to become slippery and waste foam concentrate.

If not wired to the fire pump switch as described, a main separate fused ON/OFF switch may be provided to power up the CMS.

If valves are to be used manually during system failure, a switch must be installed to remove power from the CMS for the valves to be operated manually.

**CAUTION:** Low battery voltage or voltage drop can cause the system to shift tanks momentari-

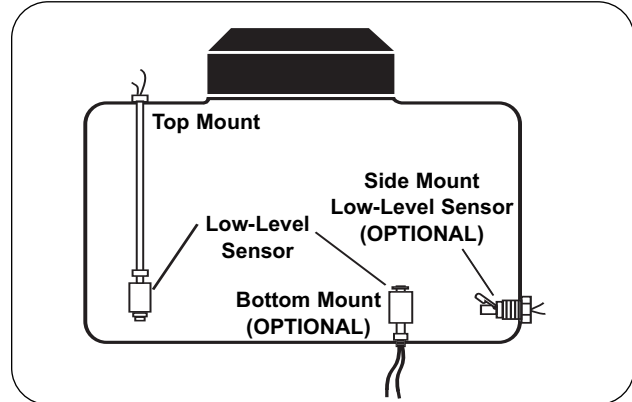

ly. Provide power from a master switch terminal. Accessories such as pump primers and lights can cause voltage drops when activated. Do not place such accessories on the same circuit.

Radios, faxes and other electrical equipment can cause power line interference. Use filters or capacitors as required to ensure that a “clean” appropriate 12 V DC or 24 V DC power source is available for the CMS control module.

An optional flush indicator lamp may be installed to provide positive indication of flush functions. (See diagram on Page 8).

## FOAM TANK LEVEL SENSOR

A foam tank level sensor must be mounted into the bottom of each foam tank to monitor low concentrate condition. The sensor has 1/8 inch NPT threads. Mount the sensor in the bottom of the foam tank in an upright position. Use suitable sealant to prevent concentrate leakage. There must be room under the tank to route the cable back to the pump/motor base unit.

When the bottom of the tank is not accessible, the low-level sensor float switches can be hung from a long nipple attached to the top of the tank. Make sure the nipple is strong enough to withstand the force of sloshing foam when the vehicle is in motion. Since wire connections must be made inside the nipple, a 3/8 inch NPT nipple with a 3/8 x 1/8 inch NPT reducer at the lower end is the minimum recommended size.

# Electronic Concentrate Management System

## Installation and Operation Manual

Check the low-level sensor with a powered test light. With no foam in the tank, the switch contacts should be closed and the test light should be on. If this is not the case, remove the clip from the end of the low-tank sensor. Remove the float and reinstall 180° out of position. Reinstall clip. Retest the switch to ensure it is working properly.

A side-mount, tank level sensor is available to be used if both the top and bottom of the foam tank is not accessible. The side-mount, tank level sensor has 1/2 inch NPT threads and must be installed as close to the bottom of the foam tank as possible. After installation, the sensor must be sealed with a suitable sealant to prevent concentrate leakage. Check the

side-mount, tank level sensor with a powered test light. With no foam in the tank, the light should be on. If the light does not come on, reposition the switch until the test light is on. Reseal the switch to prevent concentrate leakage after the switch is in the proper position.

**NOTE:** Install low-level sensor not to interfere with tank discharge.

**NOTE:** Failure to install low-tank switches will void the FoamPro warranty.

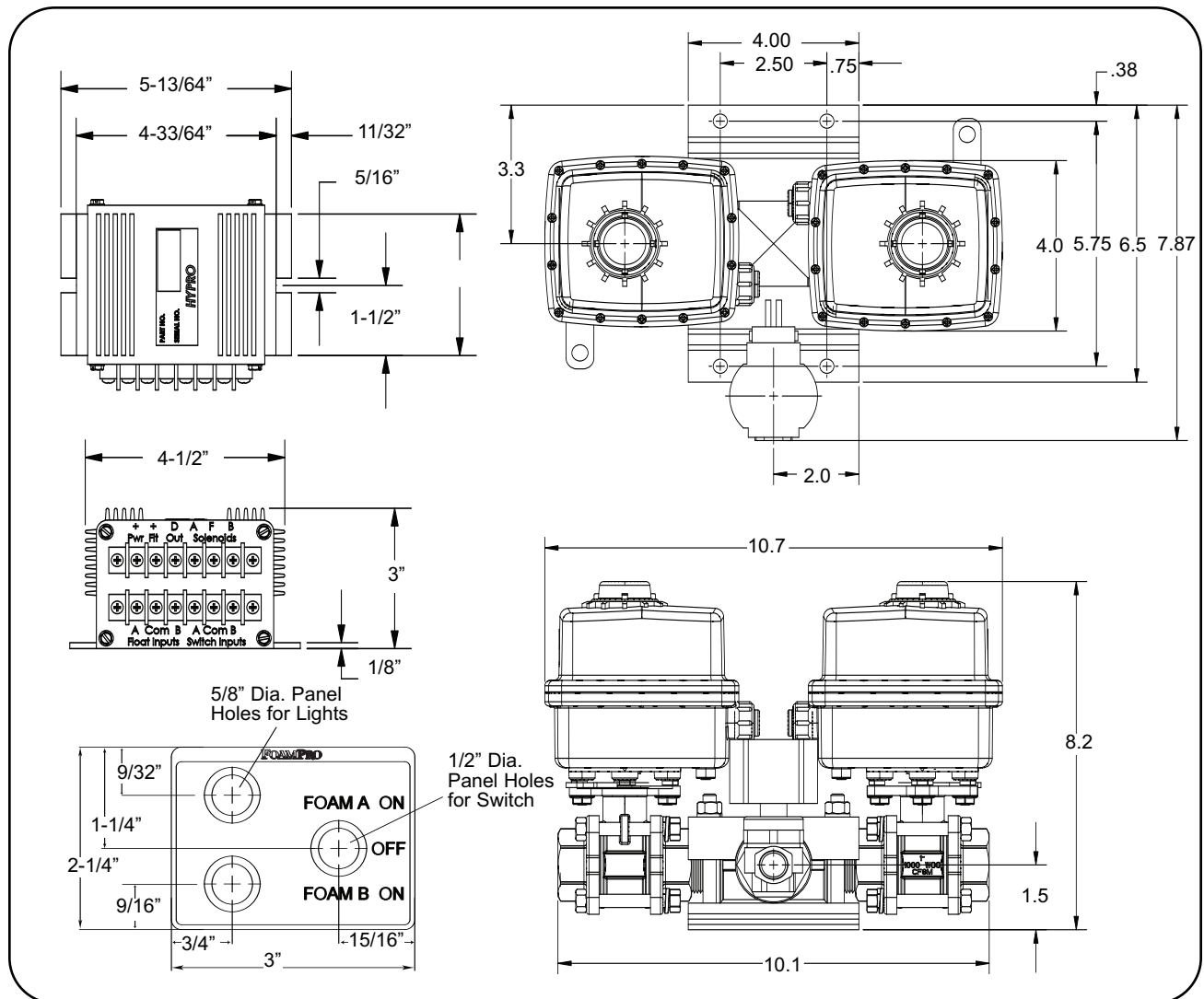

# Concentrate Management System Electrical Hookup Standard Controller

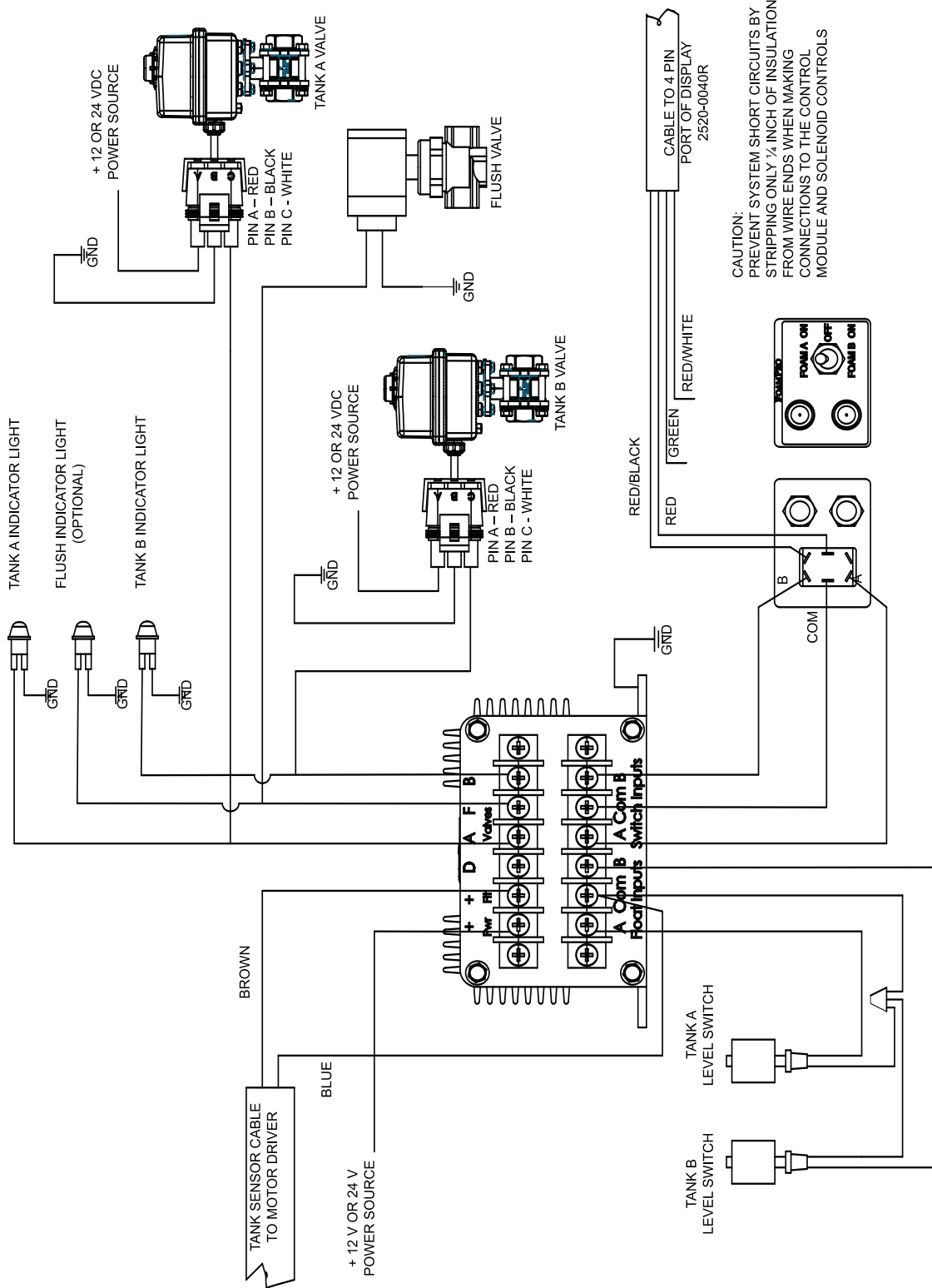

# Concentrate Management System Electrical Hookup AFC Controller

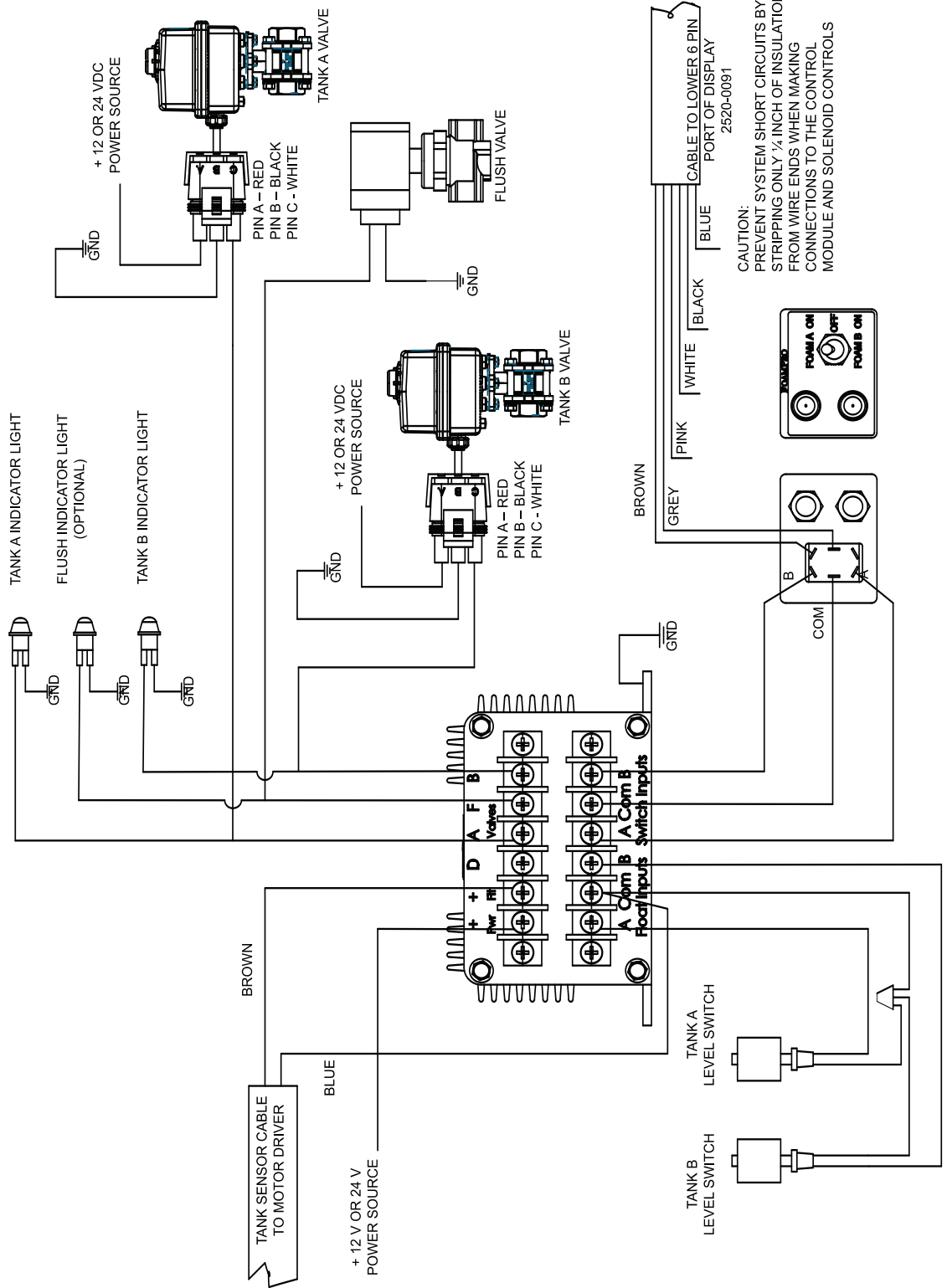

## 8 Operating Instructions

Select the desired foam tank using the toggle switch. A flush cycle will occur for 8 seconds when switching between tanks or when the system is powered up in a tank position. This cycle consists of an 8 second flush. Flush is activated for approximately 1 minute when the switch is in the “off” or flush (center) position.

Vacuum tests should be performed with the selector in the off position to avoid foam concentrate from being drawn into the water pump. Check strainers regularly for excessive contaminants.

**NOTE:** Close shut-off valves to prevent tank

drainage when servicing strainers. Make sure valves are open and the foam pump primed prior to operating foam system. Priming is made easier by switching the CAL/INJECT valve on the FoamPro to the Calibrate position while the foam pump is operating, allowing air to escape from the foam pump and piping. When foam appears at the CAL/INJECT valve, switch the valve back to the inject position to begin proportioning.

**NOTE:** When the controller default is *not* set to “DUAL. T,” the A/B tank switch will start and stop when switching to the “B” tank. See your system installation and operation manual for changing the defaults.

---

## 9 Troubleshooting

Most Electronic Concentrate Management System problems can be traced to faulty wiring. Follow the diagrams carefully and check all connections. Make sure constant 12 V DC or 24 V DC power is supplied and solid, clean ground connections are made. Excessive electrical interference or momentary low voltage on the power line can cause erratic operation. A capacitor or filter on the power line will help to prevent power interference from affecting the control module. Make sure a “clean” appropriate power supply is available and dedicated to the control module of the Concentrate Management System.

Valves may be checked by applying power directly to each white, Pin C wire of the control wires. Valves should actuate immediately upon application of power and reset when power is removed.

Often strainers on a new installation will clog immediately due to excessive debris in the

foam tank and hoses from assembly. If strainers are clear and foam flow rate is low, debris may have become lodged in valves during assembly. Remove hose assemblies and carefully check valves for debris or obstructions that could block flow. Make sure all strainers are kept clear.

A vertical-mounted (from top or bottom of the tank) foam tank low-level sensor that has the float installed upside down will show a low concentrate reading (LO CON) on the FoamPro display even with a full tank. In this situation, remove the clip, turn the float 180° and reinstall the clip. Recheck the sensor.

Low voltage can cause the system to switch to flush intermittently. The system requires the appropriate constant voltage (12 V DC or 24 V DC) to operate properly. Make sure other accessories are not on the same line causing voltage drop power problems.

# 10 Parts Identification

### Dual-Tank Selector Electronics Kit

P/N 3435-0104 (12 V DC); 3435-0105 (24 V DC)

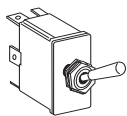

1



2



3

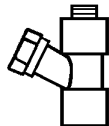

6

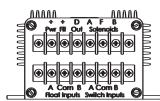

4

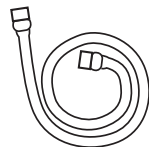

7

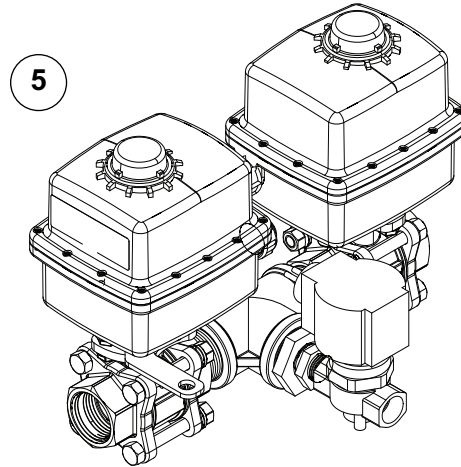

5

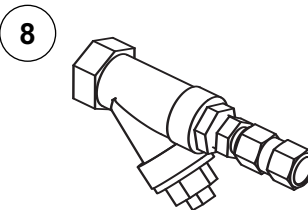

8

9

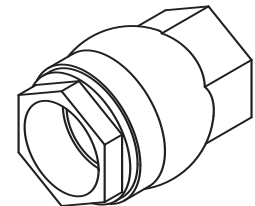

Ref.	Part No.	Description
1	2530-0050	Switch, Toggle
2	2530-0053 (12 V)	Lamp Assembly (two)
2	2530-0099 (24 V)	Lamp Assembly (two)
3	6032-0011	Placard
4	2527-0077	2-tank Electronics Module
5	3435-0136	Dual-Tank Selector Valve Assy. - 12VDC
5	3435-0137	Dual-Tank Selector Valve Assy. - 24VDC
6	3350-0136	Line Strainer (one), 1" Ports
7	2520-0040R	Control Cable Interface
8	3430-0624	Flush Check Valve and Line Strainer
9	3320-0044	1" Foam Tank Line Check Valve (two)

**• N O T E S •**

## • N O T E S •

# 11 Warranty

FoamPro warrants to the original purchaser, each new pump, system or other product of its own manufacture, for a period of one year from the date of shipment from the factory, to be free from defects in material and workmanship under normal use and service. "Normal use and service" means not in excess of recommended maximum speeds, pressures, and temperatures, or handling fluids not compatible with components materials, as noted in applicable FoamPro product catalogs, technical literature, and instructions. This warranty shall not apply to any pump, system or other product which shall have been repaired or altered to adversely affect the performance or reliability of the pump, system or other product.

Neither this warranty nor any implied warranty apply to damage or harm caused by any or all of the following: (1) Freight damage; (2) Freezing damage; (3) Damage caused by parts and/or accessories or components not obtained from or approved by FoamPro; (4) ANY CONSEQUENTIAL OR INCIDENTAL DAMAGES, OTHER THAN INJURY TO THE PERSON, ARISING FROM THE USE OF ANY PUMP OR OTHER PRODUCT MANUFACTURED BY FOAMPRO EXCEPT in states that do not allow the exclusion or limitation of incidental or consequential damages; (5) Damage due to misapplication and/or misuse; (6) Normal wear of moving parts or components affected by moving parts.

The liability of FoamPro under the foregoing warranty is limited to the repair or replacement at FoamPro's option without charge for labor or materials of any parts upon return of the entire pump, system or other product or of the particular part to the FoamPro factory within the warranty period, at the sole expense of the purchaser, which part shall upon examination appear to FoamPro's satisfaction to have been defective in material and workmanship.

The liability of FoamPro under any theory of recovery (except any express warranty where the remedy is set forth in the above paragraph) for loss, harm or damage, shall be limited to the lesser of the actual loss, harm or damage or the purchase price of the involved pump, system or other product when sold by FoamPro to its customer.

FoamPro expressly warrants its pumps and other products as above stated. THERE ARE NO OTHER EXPRESS WARRANTIES. ANY IMPLIED WARRANTIES, INCLUDING IMPLIED WARRANTY OF MERCHANTABILITY OR OF FITNESS FOR A PARTICULAR PURPOSE, ARE LIMITED IN DURATION TO ONE YEAR FROM THE DATE OF PURCHASE BY THE ORIGINAL PURCHASER EXCEPT in states that do not allow time limitations on implied warranties. THERE IS NO IMPLIED WARRANTY OF FITNESS FOR A PARTICULAR PURPOSE OR MERCHANTABILITY WHEN THIS PRODUCT IS PUT TO RENTAL USE.

No person including any dealer or representative of FoamPro is authorized to make any representation or warranty concerning FoamPro products on behalf of FoamPro, or to assume for FoamPro the obligations contained in this warranty. FoamPro reserves the right to make changes in design and other changes and improvements upon its products without imposing any obligations upon itself to install the same, upon its existing products then in process or manufacture.

This warranty gives you specific legal rights, and you may also have other rights which vary from state to state.

### IMPORTANT NOTICE

It is imperative to package all FoamPro components properly, **before** shipment (with Return Goods Authorization attached) back to FoamPro. The FoamPro contains electronic components that may receive damage from improper shipping procedures! All FoamPro components shipped back to FoamPro will pass through Quality Control Inspection, and will be photographed after the box is opened. Any shipping damage, such as superficial scratches, nicks, etc., to the unit makes it unusable (even after the internal warranty problem is repaired) and thus must be refinished to "like-new" condition during the warranty process. *You are responsible for any physical damage occurring to FoamPro components at your facility and during shipment back to FoamPro.*

Package the FoamPro, complete with all the recommended parts the Customer Service representative requires (i.e., Digital Display control with all premolded wire cables etc.) in its original carton with the Styrofoam and other packaging materials, as it was received at your facility.

FoamPro appreciates your attention in this matter, as we feel it will help us to serve you in a better fashion, while keeping the cost of the FoamPro product competitive. Thank you.

