



Power-Fill Refill System

Models

3435-0134 (12VDC), **3435-0135** (24VDC)

3435-0118 (120VAC)

INSTALLATION AND OPERATION MANUAL

Unit
Serial
Number _____

All quality FoamPro products are ruggedly designed, accurately machined, carefully assembled, thoroughly inspected and tested. In order to maintain the high quality of your unit, and to keep it in a ready condition, it is important to follow the instructions on care and operation. Proper use and good preventive maintenance will lengthen the life of your unit. ALWAYS INCLUDE THE UNIT SERIAL NUMBER IN CORRESPONDENCE.

TABLE OF CONTENTS

Section	Page
1 SAFETY	3
2 A QUICK LOOK AT HOW THE SYSTEM WORKS	4
3 WHAT YOU GET	4
4 WHAT YOU SUPPLY	5
5 PLAN AHEAD	6
6 PLUMBING THE SYSTEM	7
7 ELECTRONIC COMPONENT INSTALLATION AND HOOK-UP	8
8 OPERATING INSTRUCTIONS	11
9 MAINTENANCE	12
10 TROUBLESHOOTING	12
11 PARTS IDENTIFICATION	14
12 WARRANTY	Back Page

NOTE TO SYSTEM INSTALLERS

IMPORTANT: Please provide a copy of the FoamPro manual to the end user of the equipment.
For additional FoamPro manuals, contact Hypro by FAX 800-323-6496, web site www.foampro.com,
or call (800) 533-9511. Request Form No. 809.

1 Safety

Please read all of the following safety precautions and follow them carefully. They are important to the prevention of personal injury or damage to the equipment.

1. **Always disconnect the power source** before servicing any part of the refill system.
2. **Release all pressure** within the system before servicing any of its component parts.
3. **Drain all liquids** from the system before servicing any of its component parts.
4. **Check all hoses** for weak or worn conditions monthly. Make sure that all connections and fittings are tight and secure.
5. **Use inlet pipe, hose, and fittings** - from the panel to the refill pump inlet - that are rated for 23 inches Hg vacuum (584 mm Hg) and 50 psi (3 BAR) pressure and are compatible with foam agents.
6. **Use discharge pipe, hose and fittings** from the pump outlet to the inlet of the foam tank that are rated for a minimum of 50 psi (3 BAR) and are compatible with foam/chemical agents.
7. **Any electrical system** has the potential to cause sparks during service. Eliminate explosive or hazardous environments during service/repair.
8. **The components and fittings** used in this system must be compatible with the foam concentrates used and pressures at which the pump system operates.
9. **CAUTION: Do not operate the system at or above a temperature of 160° F (71°C).**
10. **CAUTION: Make sure the electrical source of power for the unit is a constant 12 or 24-volt DC negative ground system for the 3435-0134 and 3435-0135 truck-mounted systems, capable of supplying 41 amps minimum. Make sure the electrical source of power for the 3435-0118 portable unit is a 120 VAC grounded circuit, capable of supplying 15 amps minimum.**
11. **CAUTION: Periodically inspect foam pump and all system components. Perform routine preventive maintenance as required.**
12. **Avoid spraying water** on the pump/motor assemblies as this could cause short circuits.
13. **WARNING: Do not pump flammable or explosive fluids such as gasoline, fuel oil, kerosene, etc. Do not use in explosive atmospheres. The refill system should be used only with fluids compatible with its component materials. Failure to follow this warning may result in personal injury and/or property damage.**
14. **Unplug** the AC-driven system when not in use.
15. **Never pull the cord** to unplug the system from the power source or to move the pump/motor assembly, as cord, plug, or pump/motor damage may occur.
16. **Never operate** unit without the GFI plug.

2 A Quick Look at How the System Works

The Power-Fill foam refill systems provide for the filling of the foam reservoirs on an apparatus without manually filling the tanks from on top of the apparatus. They are available as an on-board DC powered system with automated panel control or an off-board AC powered system with a manual ON/OFF switch.

The DC Power-Fill system provides for an automatic shut-off mode or a manual refill mode via a panel-mounted control. Pushing the green button will start the foam pump/motor in the automatic refill mode. When the tank is full, the green light will go on solid. To override the automatic mode or to run in the manual mode, push and hold the red button. To stop the operation, release the red button. Caution must be taken not to hold the red button too long or the tank could overflow.

The AC Power-Fill system provides an AC driven portable foam pump/motor assembly and a visual interface typically mounted on the apparatus panel. The foam pump/motor assembly is manually switched on and off with a momentary on switch mounted in the power cord. Switching on the pump will start the refill process. When the tank is full, an indicator light on the panel will illuminate. An additional apparatus kit is available for fitting the plumbing into other apparatus.

Both systems come with a placard, cam lock fittings for the plumbing outside the apparatus, foam pump/motor assembly, a refill wand with 6 feet of 1" ID suction hose, and a side-mount level indicator switch.

3 What You Get

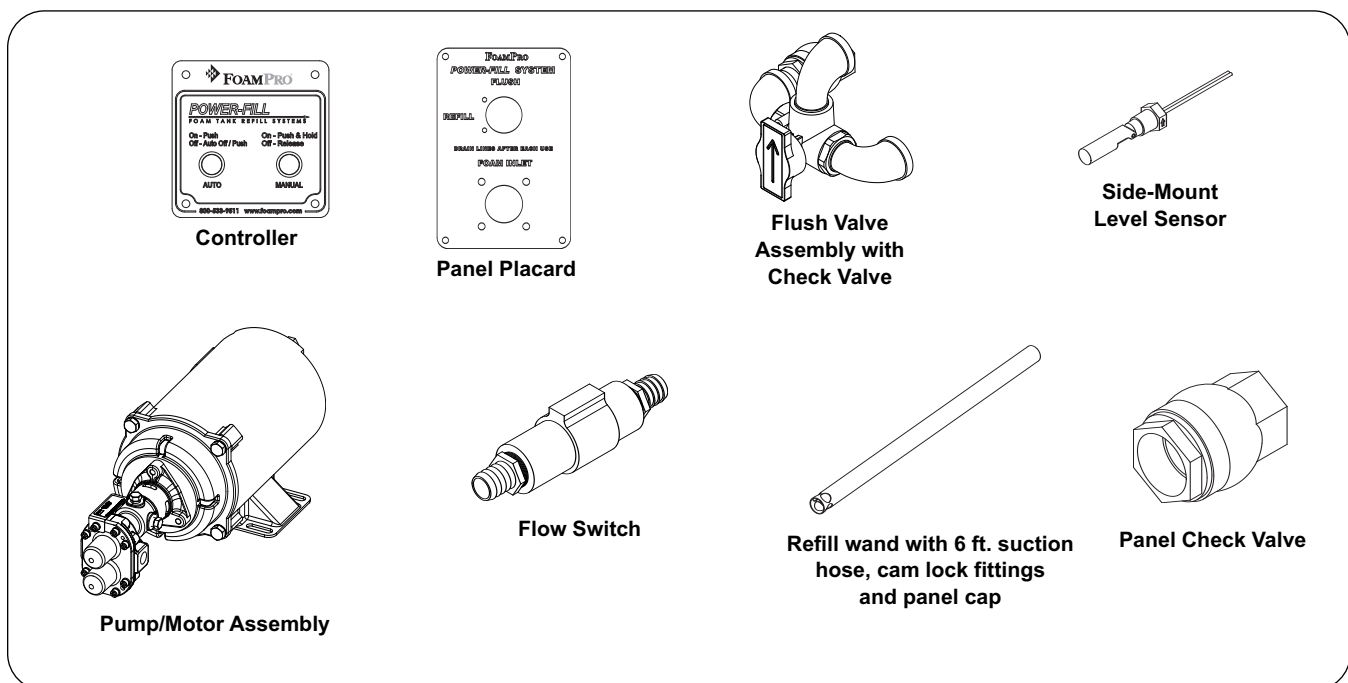

AC Portable System

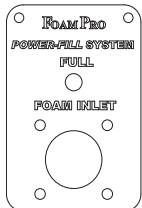

Panel placard with full lamp

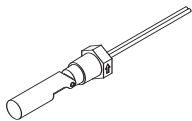

Side-mount level sensor

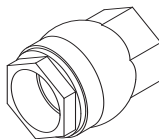

Panel Check Valve

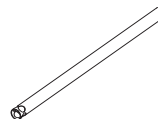

Refill wand & 6 ft. suction hose, cam lock fittings and panel cap

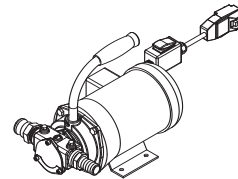

Pump/Motor Assembly

Optional System Accessories Available

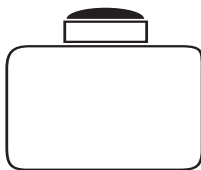

Foam Tank(s)

8 gallon, polypropylene
(P/N 1530-0005)

12 gallon, polypropylene
(P/N 1530-0012)

20 gallon, polypropylene
(P/N 1530-0022)

Requires additional hardware for compliance with the N.F.P.A.



Vertical-Mount Level Sensor
(P/N 2510-0028)

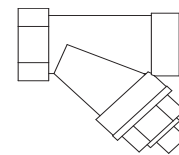

Strainer 40 Mesh
(P/N 3350-0136)

4 What You Supply

ITEMS NEEDED:

1. All fittings are to be 1" NPT and are to be compatible with the fluids being pumped (typically brass and/or stainless steel).
2. Hose on the suction side of the foam pump to be clear 1" ID suction-type hose rated for 23 inches (584mm) Hg vacuum and 50 psi (3 BAR) working pressure.
3. Hose on discharge side of foam pump to be 1" ID hose with a 50 psi (3 BAR) minimum working pressure.
4. Foam tank/tanks with two-way vent, sized to customer's specifications.

SYSTEM WIRING

Use the recommended gauge wire specified as minimum AWG wire. Use wire that is automotive type and resistant to abrasion and chemicals such as oil and foam. It is recommended that wiring be bundled with wire ties and protected with loom.

5 Plan Ahead

Because of the potential differences in fire apparatus plumbing and foam system configuration, it is not practical to depict exactly how each *Power-Fill* FoamPro unit will be installed on a particular apparatus. Most of the information contained in the following sections will apply to most situations.

Read these sections thoroughly. Plan and design where and how to install this equipment in the apparatus before beginning the actual installation. The following diagrams provide guidelines for the location of the system components. Determine the locations of the components to be installed, such as foam tanks, foam refill

pump/motor assembly, refill control panel, outboard pickup panel and placard. Try to place components in locations that will allow the least amount of hose and fittings.

Locate the foam pump/motor assembly (DC version only) in an area that is protected from road debris and excessive heat buildup. The foam pump/motor assembly should be located as close to the outboard pickup and placard as possible. Locate the outboard pickup and placard low on the control panel with the control module close by.

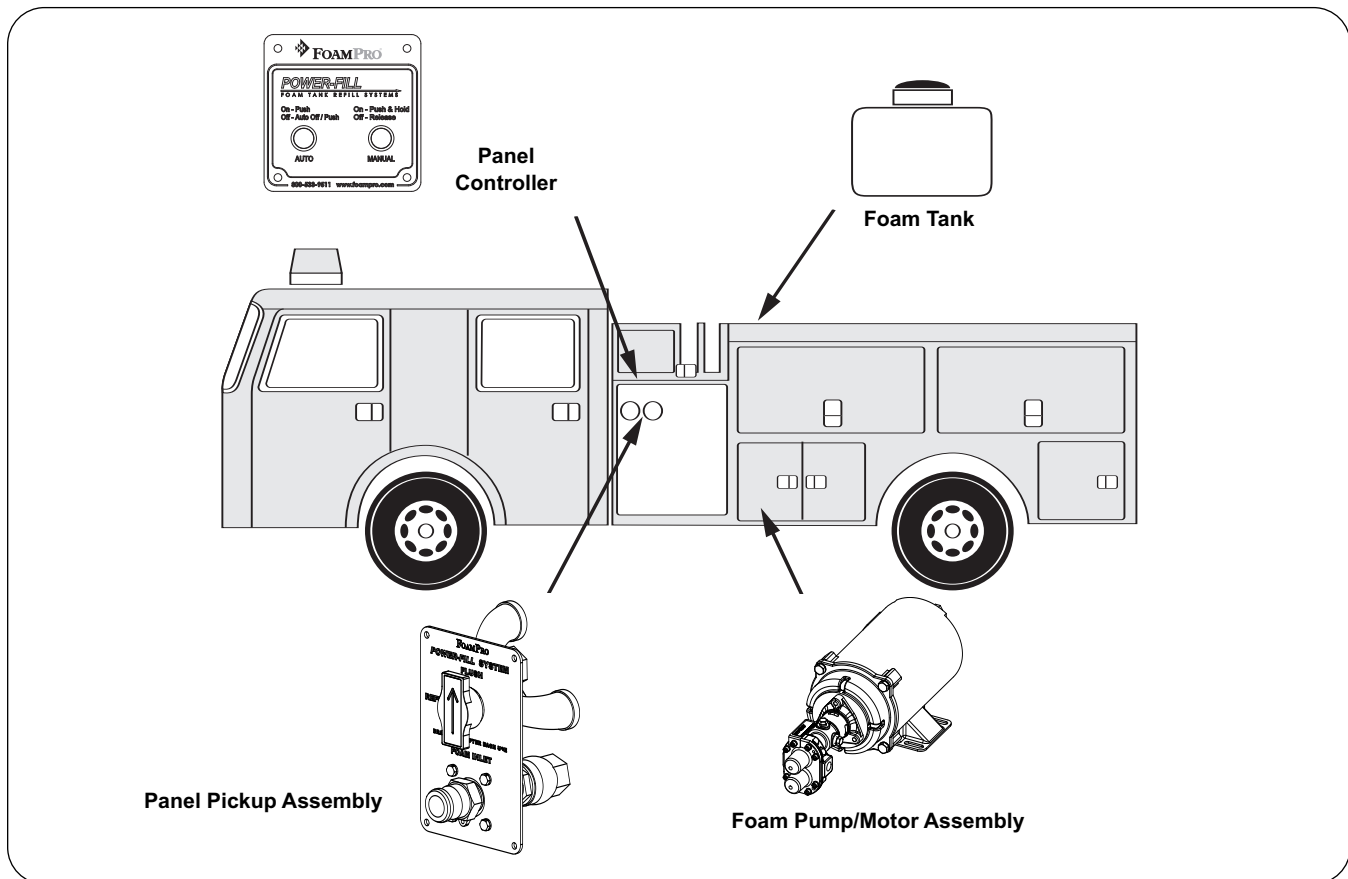

6 Plumbing the System

The system schematic on the following pages show the plumbing for both the DC truck-mounted system and the AC portable unit.

Mount the motor and pump horizontally.

If strainers are installed, make sure they are located in an accessible location as they will require regular maintenance.

Suction hose to be rated for a minimum of 23 inches (584mm) Hg vacuum and 50 psi (3 BAR) working pressure.

All other hose to be rated for 50 psi (3 BAR).

Use the supplied plastic 1" hose barbs with the flow switch. Do not mount the flow switch directly to the pump or other rigid device. Provide proper

strain relief so that the flow switch is not supporting the hose weight. Do not mount the flow switch near the exhaust manifold or where it will be exposed to temperatures above 210°F.

All fittings are to be compatible with chemicals being pumped.

Install independent drains in lines that may cause damage if frozen.

Plumb the fill line to the lowest part of the tank and parallel to the bottom of the tank. This will eliminate cavitation in the outlet of the tank and will minimize foaming of the chemical.

Do not plumb refill discharge line directly into the FoamPro foam system inlet line.

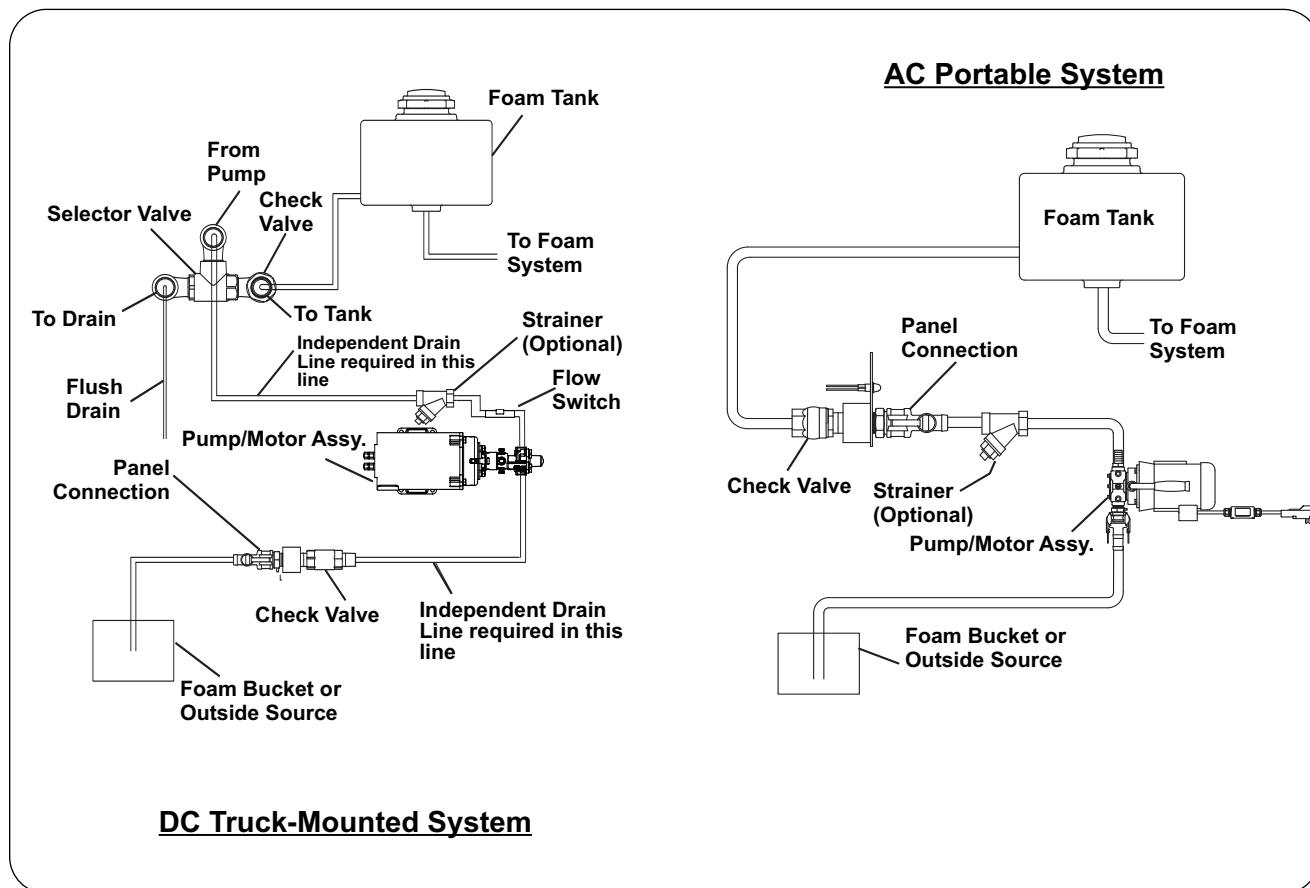

7 Electronic Component Installation and Hook-Up

The schematic on pages 9 and 10 show how to wire the electrical components for both the DC truck-mounted system and the AC portable system.

Some things to keep in mind:

Do not hook up main power until all connections have been made and are tight.

Use the recommended wire gauge specified or larger.

The system can only perform when electrical connections are sound, so make sure each one is correct and tight.

Do not mount radio transmitter or transmitter cables in direct or close contact with the system wiring.

CAUTION: Always disconnect the power and ground connections before electric arc welding at any point on the apparatus. Failure to do so will cause damage to electrical components.

Use of standard automotive wire of the size specified on the schematic that is grease and fuel resistant is recommended.

CAUTION: Low battery voltage or voltage drop may cause the system to malfunction. Provide power from a master switch terminal. Accessories, such as pump primers and lights, may cause voltage drops when activated. Do not place such accessories on the same circuit.

FOAM TANK LEVEL SENSOR

A foam tank level sensor must be mounted into the top of the foam tank to monitor full concentrate condition.

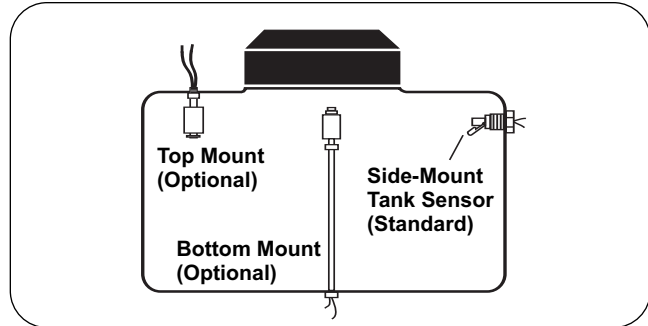

A side-mount tank level sensor is supplied with the system. If this sensor cannot be used in the apparatus being built, a top/bottom mount sensor is available (p/n 2510-0028).

The side-mount tank level sensor has 1/2-inch NPT threads and must be installed as close to the top of the foam tank as possible. After installation, the sensor must be sealed with a suitable sealant to prevent concentration leakage. Check the side-mount sensor with a powered test light. With no or low level of chemical in the tank, the test light should be off. With a full tank, the light should be on. If the light does not come on when the tank is full, reposition the sensor until the light illuminates. Reseal the switch to prevent leakage.

A top/bottom mount sensor is available. The sensor has 1/8-inch NPT threads. Mount the sensor in the top of the foam tank in a vertical position. Use suitable sealant to prevent concentrate leakage. There must be room above the tank to route the cable back to the control unit.

Check the tank level sensor with a powered test light. With no foam in the tank, the switch contacts should be open and the test light should be off. If this is not the case, remove the clip from the end of the low-level sensor. Remove the float and reinstall 180° out of position.

NOTE: Failure to install low-level switches will void the FoamPro warranty.

DC Truck-Mounted System

Provide adequate electrical power (41 amps @13.5V DC, 21 amps @ 27V DC) from the battery. Use 8 AWG wire directly from the battery or battery switch. Long wire runs will require a larger gauge wire for proper operation. Use the following as guidelines for longer wire runs.

Wire Size	Wire Length
8 AWG	10 feet or less
6 AWG	10-20 feet
4 AWG	20 feet or more

Electrical devices can be easily damaged by a weak or erratic power supply. The Power-Fill system is no different - the better the power supply, the better the system will perform.

DO NOT connect the main power to leads that supply power to some other device, such as a light bar, siren, or primer pump.

NOTE: Any system without a flow switch will require Jumper 2520-0118 or system will shut down automatically after 20 seconds.

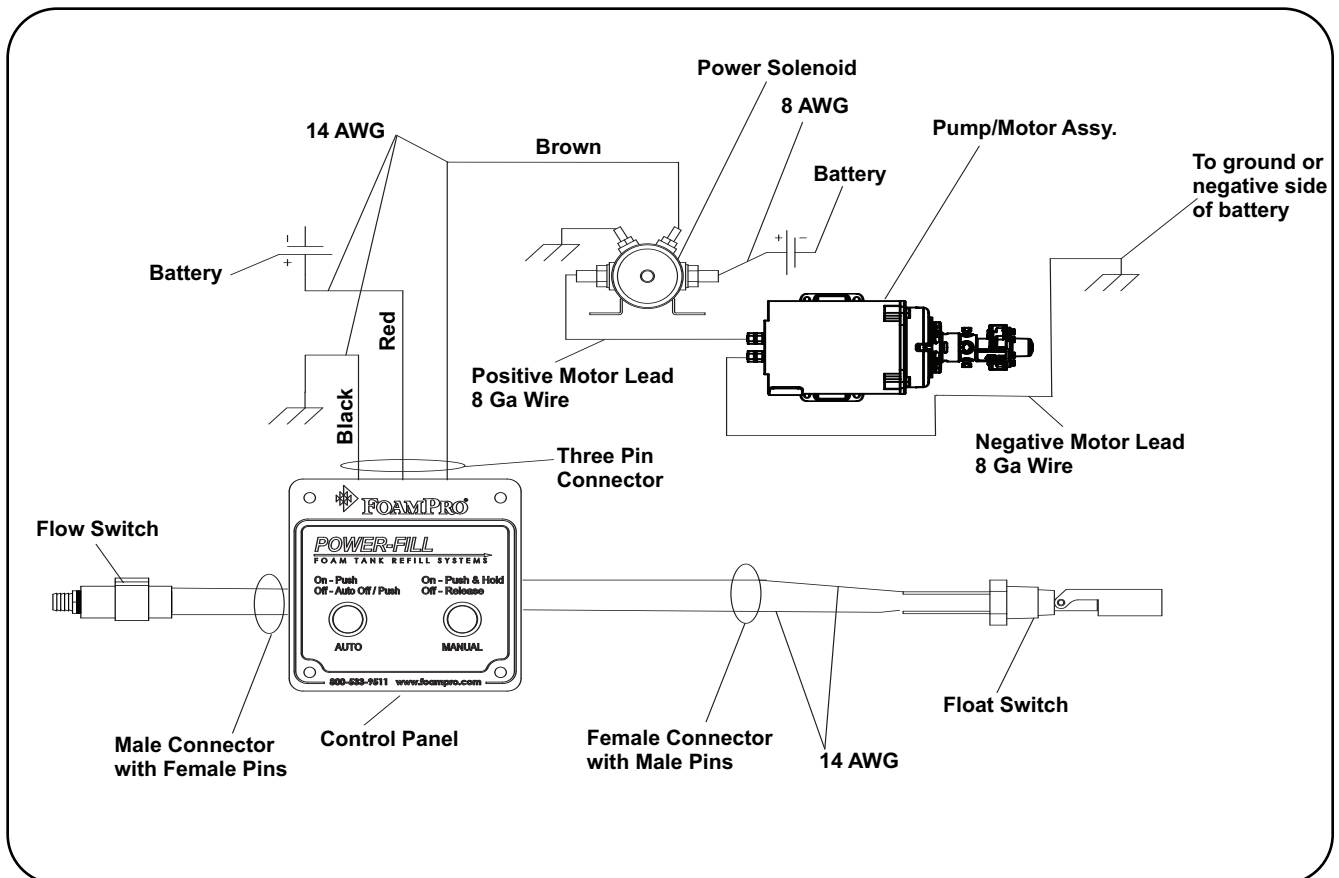

AC Portable System

The Power-Fill AC system requires a 120 VAC standard power source with 15 amp circuit protection. A ground fault interrupter is attached to the cord for safety. DO NOT remove the GFI from the cord or operate the system without a GFI in the line. The tank level indicator on the panel requires 12 V DC power from the battery or master switch. This line can be wired with 14 AWG automotive-type hookup wire.

DO NOT remove GFI from power cord.

The use of an excessively long extension cord is not recommended and will affect the performance of the system.

If the power cord becomes frayed or damaged, replace the entire cord.

Unplug the main power source when unit is not in use.

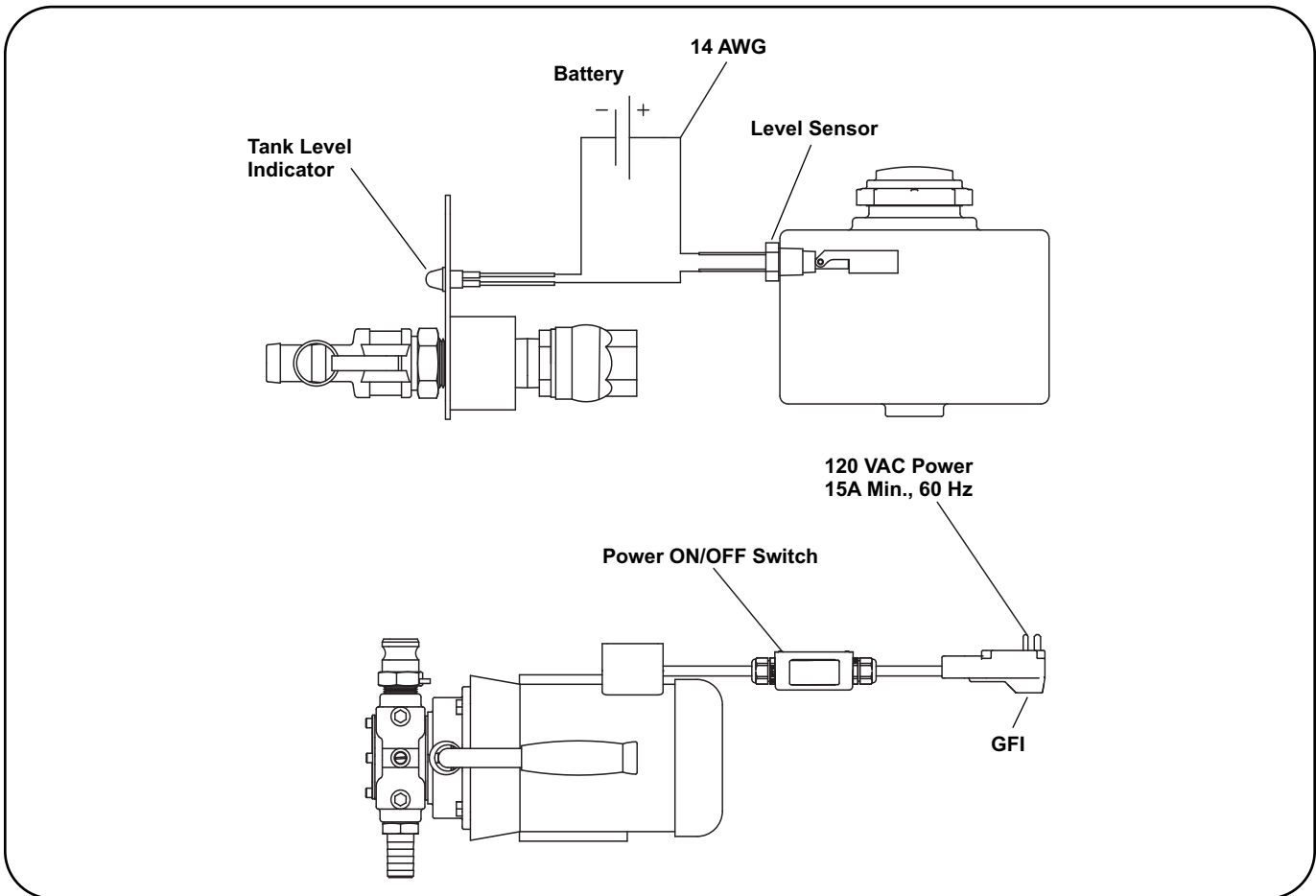

8 Operating Instructions

DC Truck-Mounted System

By following the steps listed below, the DC truck-mounted Power-Fill system can be easily operated.

Automatic Refill Operation

1. Connect the outboard pickup hose and wand onto the outboard pickup fitting on the panel.
2. Place the wand end into the foam container.
3. Turn the refill/flush valve counterclockwise to the stop for the refill position.
4. Press the "GREEN" button once. The pump will start filling the foam tank. The "GREEN" light will flash on and off while the pump is in operation.
5. When the foam tank is full, the "GREEN" light will illuminate solid and the pump will stop.

Pay close attention to the operation. If the foam source runs out of fluid before the tank is full, press the "GREEN" button again to stop pumping operation. Place the wand in a fresh container of foam and restart the operation by pressing the "GREEN" button.

DO NOT allow pump to run without fluid being pumped, as damage to the pump will occur.

6. Pump will run for 20 seconds and then shut down if no flow is detected by the flow switch. After 20 seconds, the pump will shut down immediately after no flow is detected.
7. When the foam level drops in the foam tank, the "GREEN" light will go out.

Manual Refill Operation

1. Repeat steps 1 through 3 above.
2. Press and hold the "RED" button to run the pump. The button will illuminate solid red while the pump is running.

3. When the tank is full, as shown by the solid "GREEN" light, release the "RED" button.

Note: When operating the system manually, the pump will not shut off automatically when the tank is full.

Flush Operation

1. Turn the refill/flush valve handle clockwise to the stop for the flush position.
2. Place the pickup wand into a container of fresh water.
3. Place an empty container under the flush drain line.
4. Depress and hold the "RED" button until discharge fluid is clear.
5. Release "RED" button.
6. Drain Power-Fill lines after each flush to prevent freezing and/or contamination of foam.

NOTE: Pump comes filled with Mineral Oil in seal case port (see diagram page 16).

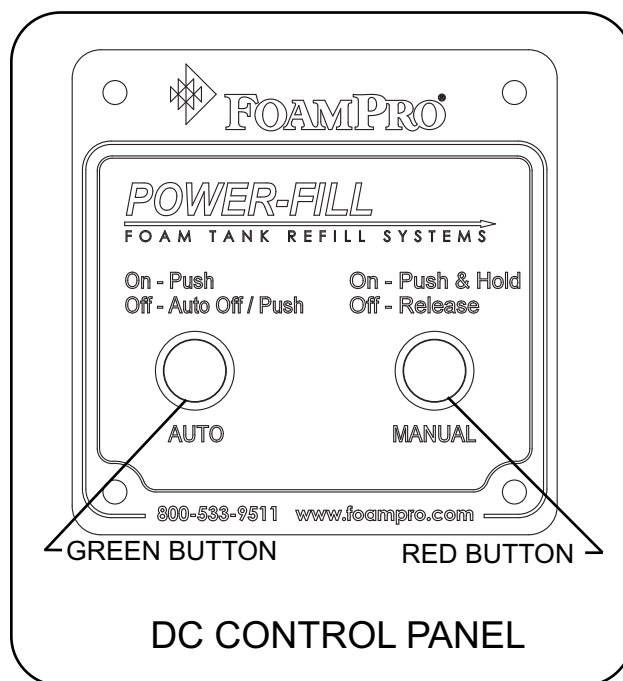

AC Portable System

By following the steps listed below, the AC powered portable Power-Fill system can be easily operated.

Refill Operation

1. Connect refill hose from pump discharge to the outboard pickup fitting on the panel.
2. Place the wand end of the pump suction hose into the foam container.
3. Plug the electrical cord with GFI into a standard 120 VAC outlet.
4. Depress rocker switch on power cord. This will run the foam refill pump.
5. When tank is full, the "GREEN" light on the panel will illuminate.
6. Release the rocker switch and the switch will turn off the foam refill pump.

Flush Operation

1. Place wand in container of fresh water.
2. Place end of pump discharge hose in empty container.
3. Run refill pump by depressing rocker switch, until discharged fluid is clear.
4. Release rocker switch.
5. Drain Power-Fill lines after each flush to prevent freezing and/or contamination of foam.
6. Unplug power cord from receptical and store unit.

9 Maintenance

Once a year, check all hose and wire connections. Check all components for signs of external wear.

10 Troubleshooting

Most electrical system problems can be traced to faulty wiring. Follow the diagrams carefully and check all connections. Make sure the proper power is being supplied and solid, clean ground connections are made. Excessive electrical interference or momentary low voltage on the power line may cause erratic operation.

Following the troubleshooting guide will allow quick diagnosis of the problem and the corrective action to take.

Symptom	Probable Cause(s)	Corrective Action
Pump loses prime, chatters, flow fluctuates.	Air leak in suction line.	Remove suction hose and test for leaks by pressurizing hose with water. Make sure thread sealant has been used on all fittings.
	Suction line is blocked, collapsed or too small.	Remove suction line and inspect for loose liner or debris lodged in hose. Avoid all unnecessary bends. Do not kink hose.
	Debris in pump, worn pump impeller.	Remove pump end plate and check for debris and/or impeller wear.
	Clogged strainer.	Clean strainer if present.

TROUBLESHOOTING GUIDE (cont'd.)

Symptom	Probable Cause(s)	Corrective Action
Pump runs, but at a reduced speed.	Ground wire not large enough or not solid. Debris in pump.. Inadequate voltage. Clogged strainer. Discharge pressure too high.	Check wire for damage, size, and all connections. Remove pump end plate and check for debris. Check for proper voltage requirements. Clean strainer if present. Check discharge lines for restrictions or closed valves.
Full light is illuminated with empty or not-full tank condition.	Tank level sensor out of adjustment. Tank level sensor wiring shorted. Tank level sensor is stuck.	Check level sensor for proper positioning (see installation instructions). Check level sensor for frayed or damaged wires. Clean level sensor.
Pump switch is activated, but pump will not run.	DC Model: Inadequate voltage. Ground or power wires not large enough or not clean connections. Motor solenoid damaged. Damaged motor.	Check for proper voltage requirements. Check wires for proper size, damage and solid connections. Check all connections and power voltage to solenoid actuator post. With actuator post powered at DC line voltage, the output (motor connection) is to be at line voltage. If not, replace solenoid. Check motor by supplying voltage directly to motor terminals. If motor does not run, replace motor.
Pump runs for 20 seconds and then shuts off.	DC model pump not priming. Flow switch mounted backwards. Flow switch not connected. No flow switch connected. Red light flashes On/Off. AC Model: GFI tripped. GFI will not reset, but cord, motor, and switch are not damaged. Damaged power cord or switch. Damaged motor.	Check for plugged strainer. Check for air leak in suction hose. Check orientation of flow switch. Check flow switch connection and function. Use Jumper 2520-0118. Check flow switch. Check for damaged power cord and reset GFI. If GFI will not reset, check for damaged wiring in motor or improper voltage supply. Replace power cord. Replace power cord. Check motor by supplying line voltage directly to motor terminals. If motor does not run, replace motor.

11 Parts Identification

DC Truck-Mounted System

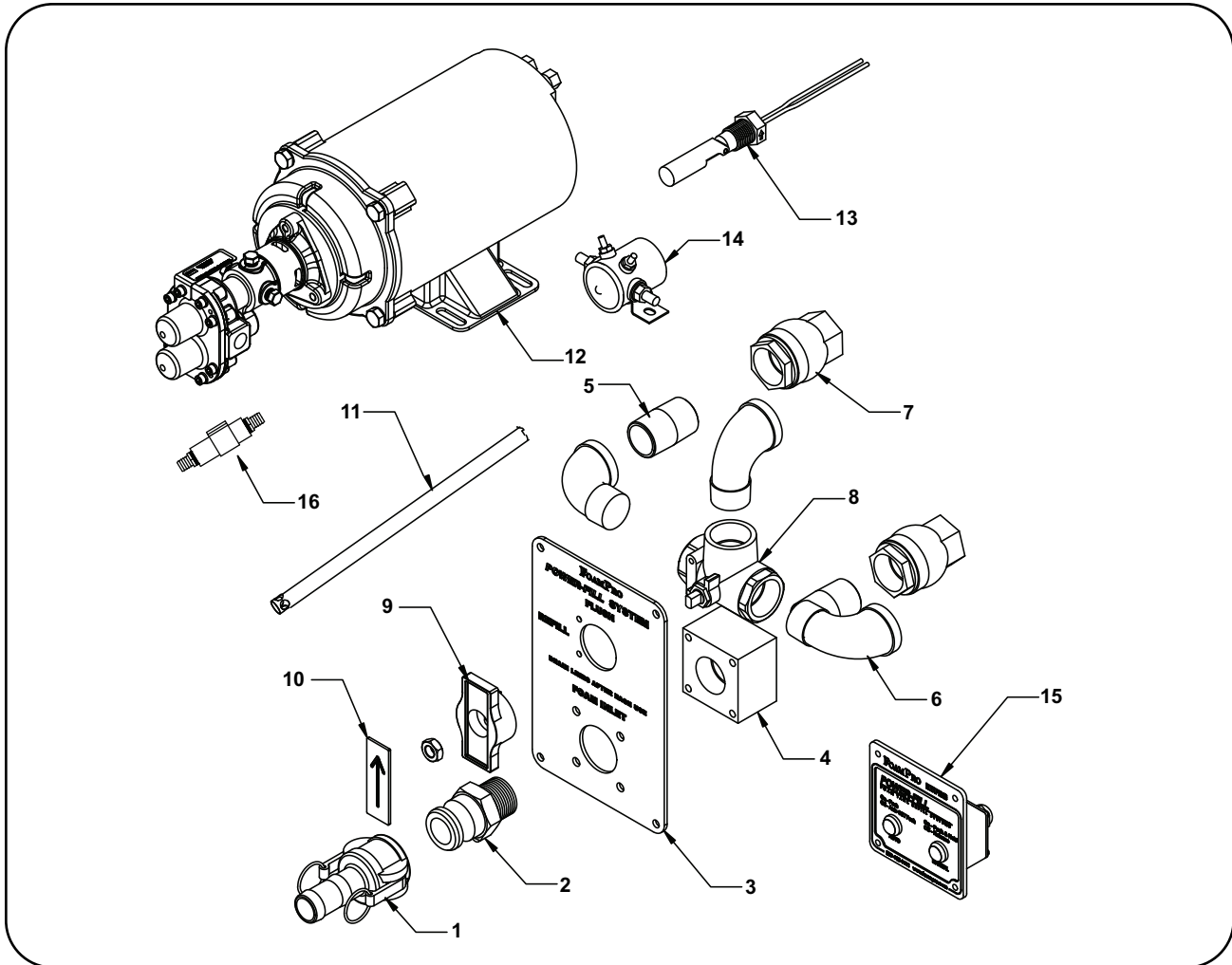

Item	Part No.	Description	QTY	Item	Part No.	Description	QTY
1	18104C	Cam Lock	1	10	6031-0487	Label	1
	18104H	Cam Lock Cap	1	11	2900-0077	Refill Wand	1
2	F-100SS	Cam Lock Adapter	1	12	3450-0056	Pump/Motor Assy.	1
3	6032-0038	Placard	1	13	2510-0032	Level Sensor	1
4	2404-0337	Panel Block	1	14	2525-0029	Solenoid - 12 VDC	1
5	2402-0043	Nipple, 1" NPT	2	15	2527-0079	Controller	1
6	7SE100	Elbow, 1" NPT	3	16	3430-0706	Flow Switch Assy.	1
7	3320-0044	Check Valve	2				
8	3304-0027	Ball Valve, 3-Way	1	Not Shown:	2900-0078	Suction Hose 1" ID	6 FT
9	2800-0028	Handle	1		2910-0017	Hose Clamp	2

No. 3430-0705 Wand Kit - Consists of Items 1 and 11, suction hose and clamps.

AC Portable System

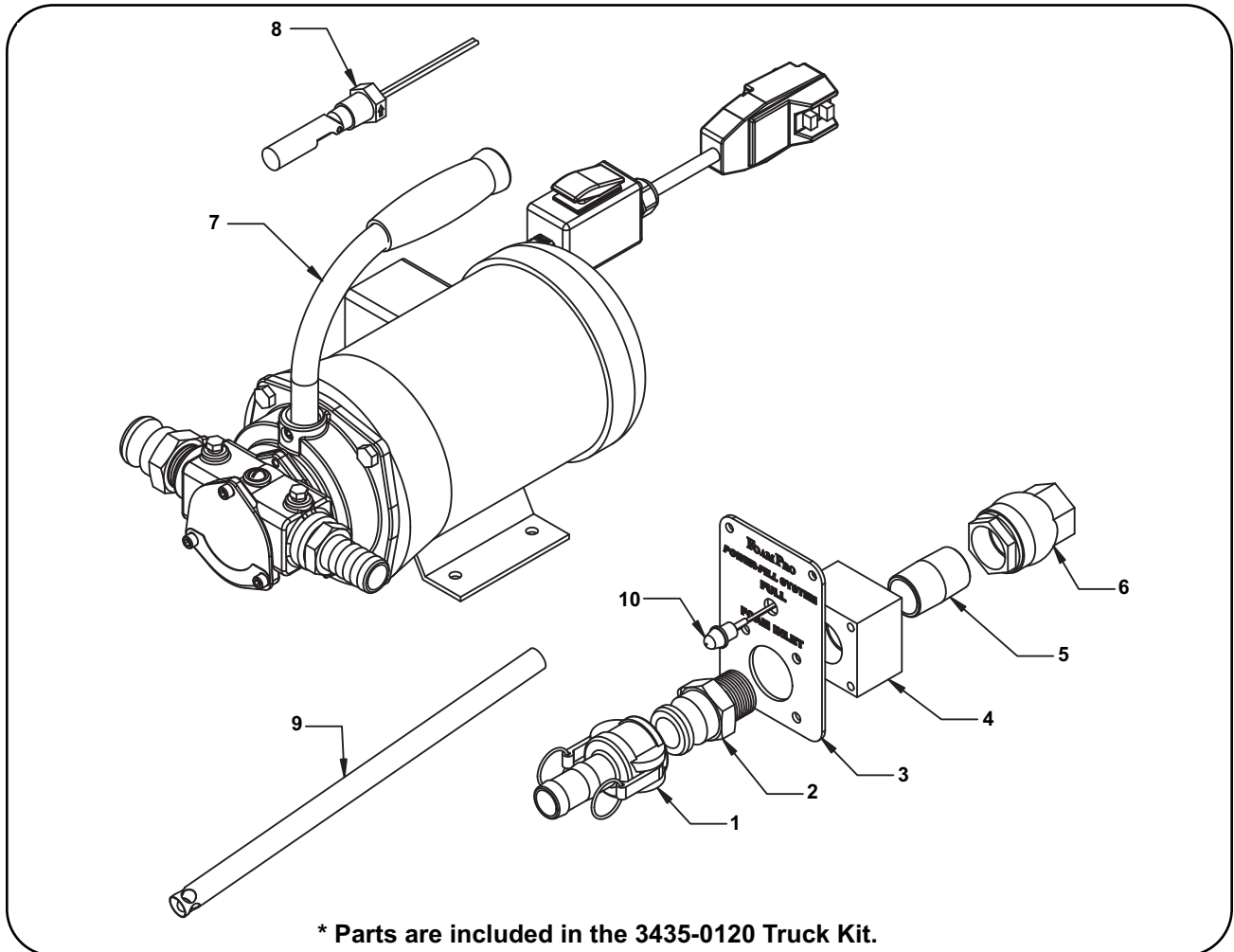

Item	Part No.	Description	QTY	Item	Part No.	Description	QTY
1*	18104C	Cam Lock	2	7	3450-0049	Pump/Motor Assy.	1
*	18104H	Cam Lock Cap	1		MRB15001	Pump Assy.	1
2*	F-100SS	Cam Lock Adapter	1		2520-0092	Power Cord	1
3*	6032-0039	Placard	1	8*	2510-0032	Level Sensor	1
4*	2404-0337	Panel Block	1				1
5*	2402-0043	Nipple, 1" NPT	1	9	2900-0077	Refill Wand	1
6*	3320-0044	Check Valve	1	10*	2530-0109	Lamp Assembly	1
				Not Shown:			
				*	2900-0078	Suction Hose 1" ID	6 FT
				*	2910-0017	Hose Clamp	2

No. 3430-0705 Wand Kit - Consists of Items 1 and 11, suction hose and clamps.

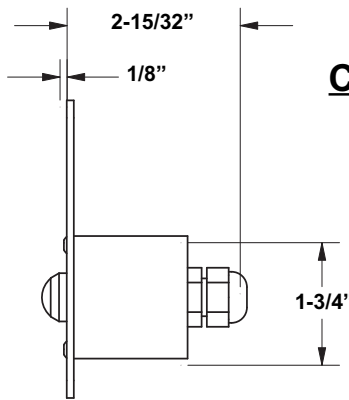
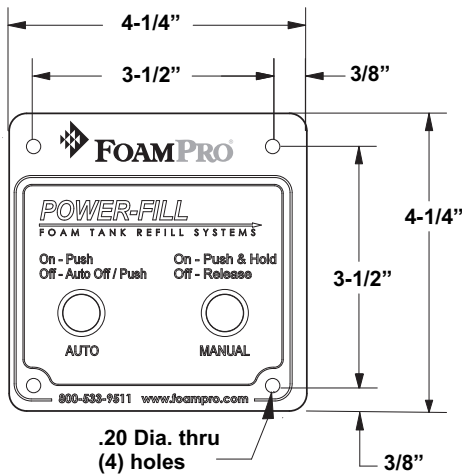
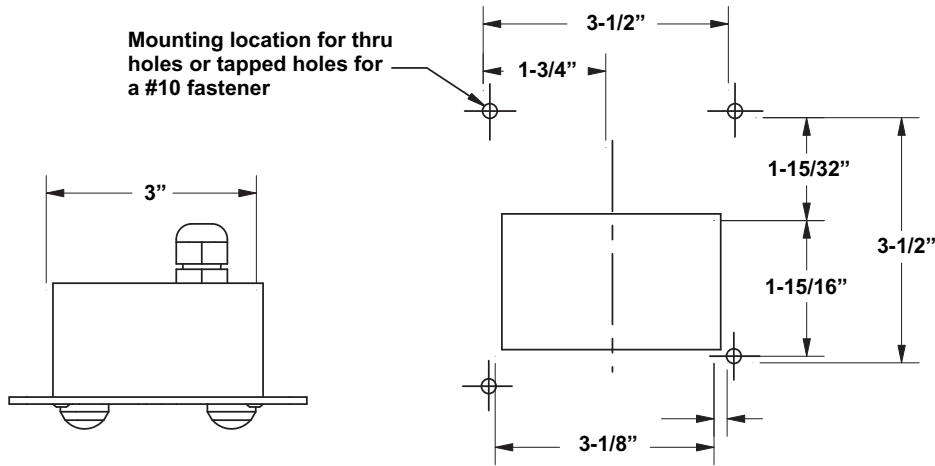

**DC TRUCK SYSTEM
CONTROLLER LAYOUT**

**DC TRUCK SYSTEM
PUMP/MOTOR LAYOUT**

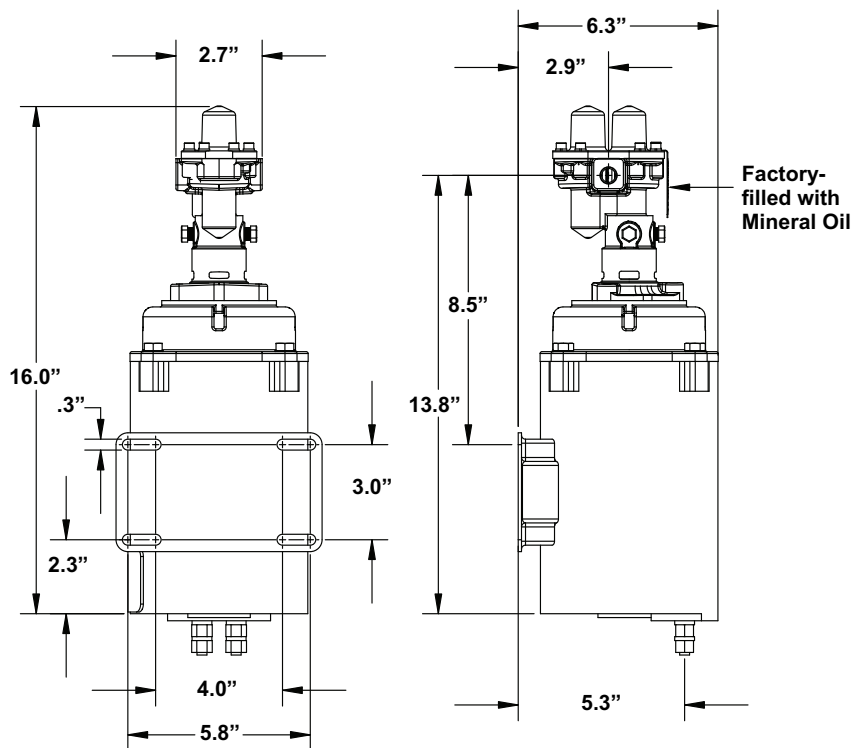

Power-Fill System

Installation and Operation Manual

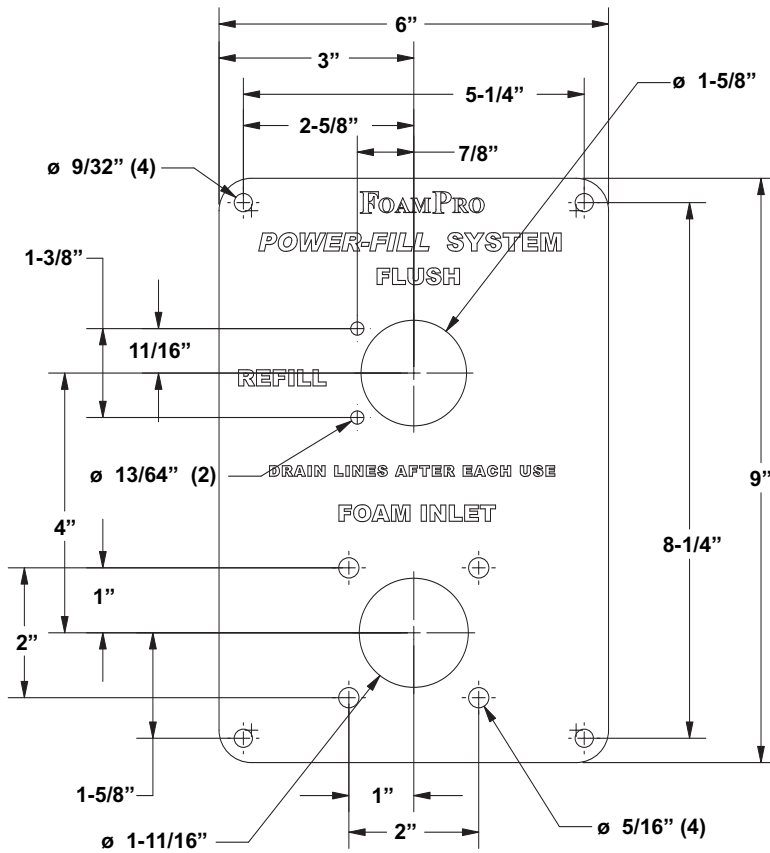

**DC TRUCK SYSTEM
PLACARD LAYOUT**

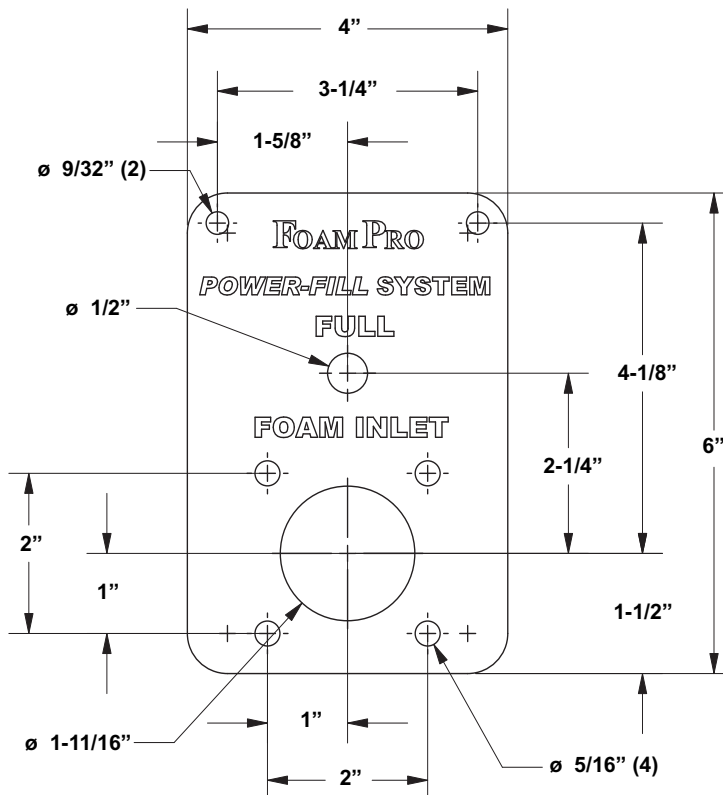

**AC PORTABLE SYSTEM
PLACARD LAYOUT**

NOTES

NOTES

12 Warranty

FoamPro, warrants to the original purchaser, each new pump, system or other product of its own manufacture, for a period of one year from the date of shipment from the factory, to be free from defects in material and workmanship under normal use and service. "Normal use and service" means not in excess of recommended maximum speeds, pressures, and temperatures, or handling fluids not compatible with components materials, as noted in applicable Hypro product catalogs, technical literature, and instructions. This warranty shall not apply to any pump, system or other product which shall have been repaired or altered to adversely affect the performance or reliability of the pump, system or other product.

Neither this warranty nor any implied warranty apply to damage or harm caused by any or all of the following: (1) Freight damage; (2) Freezing damage; (3) Damage caused by parts and/or accessories or components not obtained from or approved by FoamPro; (4) ANY CONSEQUENTIAL OR INCIDENTAL DAMAGES, OTHER THAN INJURY TO THE PERSON, ARISING FROM THE USE OF ANY PUMP OR OTHER PRODUCT MANUFACTURED BY FOAMPRO EXCEPT in states that do not allow the exclusion or limitation of incidental or consequential damages; (5) Damage due to misapplication and/or misuse; (6) Normal wear of moving parts or components affected by moving parts.

The liability of FoamPro under the foregoing warranty is limited to the repair or replacement at FoamPro's option without charge for labor or materials of any parts upon return of the entire pump, system or other product or of the particular part to the FoamPro factory within the warranty period, at the sole expense of the purchaser, which part shall upon examination appear to FoamPro's satisfaction to have been defective in material and workmanship.

The liability of FoamPro under any theory of recovery (except any express warranty where the remedy is set forth in the above paragraph) for loss, harm or damage, shall be limited to the lesser of the actual loss, harm or damage or the purchase price of the involved pump, system or other product when sold by FOAMPRO to its customer.

FoamPro expressly warrants its pumps and other products as above stated. THERE ARE NO OTHER EXPRESS WARRANTIES. ANY IMPLIED WARRANTIES, INCLUDING IMPLIED WARRANTY OF MERCHANTABILITY OR OF FITNESS FOR A PARTICULAR PURPOSE, ARE LIMITED IN DURATION TO ONE YEAR FROM THE DATE OF PURCHASE BY THE ORIGINAL PURCHASER EXCEPT in states that do not allow time limitations on implied warranties. THERE IS NO IMPLIED WARRANTY OF FITNESS FOR A PARTICULAR PURPOSE OR MERCHANTABILITY WHEN THIS PRODUCT IS PUT TO RENTAL USE.

No person including any dealer or representative of FoamPro is authorized to make any representation or warranty concerning FoamPro products on behalf of FoamPro, or to assume for FoamPro the obligations contained in this warranty. FoamPro reserves the right to make changes in design and other changes and improvements upon its products without imposing any obligations upon itself to install the same, upon its existing products then in process or manufacture.

This warranty gives you specific legal rights, and you may also have other rights which vary from state to state.

IMPORTANT NOTICE

It is imperative to package all FoamPro components properly, **before** shipment (with Return Goods Authorization attached) back to FoamPro. The FoamPro contains electronic components that may receive damage from improper shipping procedures! All FoamPro components shipped back to FoamPro will pass through Quality Control Inspection, and will be photographed after the box is opened. Any shipping damage, such as superficial scratches, nicks, etc., to the unit makes it unusable (even after the internal warranty problem is repaired) and thus must be refinished to "like-new" condition during the warranty process. *You are responsible for any physical damage occurring to FoamPro components at your facility and during shipment back to FoamPro.*

Package the FoamPro, complete with all the recommended parts the Customer Service Representative requires (i.e., Digital Display control with all premolded wire cables etc.) in its original carton with the Styrofoam and other packaging materials, as it was received at your facility.

FoamPro appreciates your attention in this matter, as we feel it will help us to serve you in a better fashion, while keeping the cost of the FoamPro product competitive. Thank you.